

PCE Datenblatt

Artikel-Nr.	090PV032
Bezeichnung	PV-BOX SOL-LINE DC2-SICH-M16-TYP2 IP54
Langbeschreibung	Systemlösung Typ 2 für PV-Anlagen mit 2 MPP-Tracker, 1000V DC Kunststoffgehäuse (310x246x148mm) mit transparentem Fenster für max. 12 Teilungseinheiten Anzahl MPP-Tracker: 2 / Anzahl Strings pro MPP: 1 2x Überspannungsableiter Typ 2 (PC) 8x Kabelverschraubung M16 4x Sicherungseinsatz 16A gPV 1000V DC (PC) 2x Kabelverschraubungen M16 für Schutzleiteranschluss Schutzart: IP54
GTIN (EAN)	9003399529689
Ursprungsland	PL
Zolltarifnummer	85371098
Nettogewicht	1,350 kg
Verpackungsmenge	1
Mindestbestellmenge	1

ETIM 8.0	EC003857
----------	----------

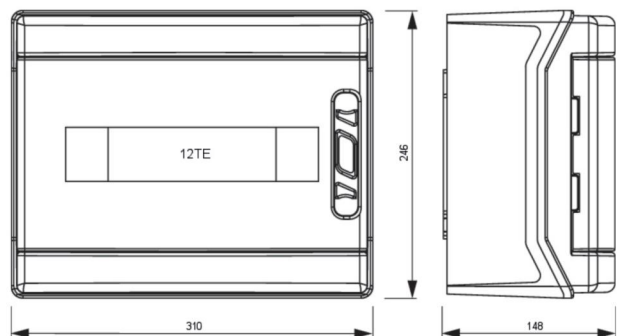

<https://www.pcelectric.at/shop/de/?func=detail&artnr=090PV032>



www.manufacturer-safety.info