

## PCE Datenblatt

Artikel-Nr.	<b>090PV001</b>
Bezeichnung	<b>PV-BOX SOL-LINE DC2-SICH-MC-TYP1+2 IP54</b>
Langbeschreibung	Systemlösung Typ 1+2 für PV-Anlagen mit 2 MPP-Tracker, 1000V DC Kunststoffgehäuse (310x246x148mm) mit transparentem Fenster für max. 12 Teilungseinheiten Anzahl MPP-Tracker: 2 / Anzahl Strings pro MPP: 1 2x Blitzstrom-/Überspannungsableiter Typ 1+2 (PC) 8x PV-Steckverbinder 4x Sicherungseinsatz 16A gPV 1000V DC (PC) 2x Kabelverschraubungen M16 für Schutzleiteranschluss fertig verdrahtet Schutzart: IP54
GTIN (EAN)	9003399475344
Ursprungsland	PL
Zolltarifnummer	85371098
Nettogewicht	2,600 kg
Verpackungsmenge	1
Mindestbestellmenge	1
ETIM 8.0	EC003857

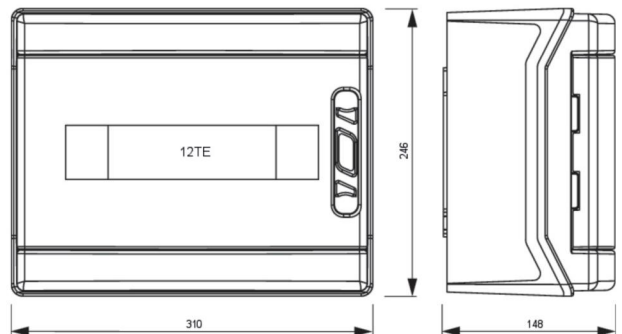

<https://www.pcelectric.at/shop/de/?func=detail&artnr=090PV001>



[www.manufacturer-safety.info](http://www.manufacturer-safety.info)