

# PCE Datenblatt

Artikel-Nr.	<b>090PV027</b>
Bezeichnung	<b>PV-BOX SOL-LINE DC1-M16-TYP1/2 IP54</b>
Langbeschreibung	Systemlösung Typ 1+2 für PV-Anlagen mit 1 MPP-Tracker, 1000V DC Kunststoffgehäuse (238x231x118mm) mit transparentem Fenster für max. 8 Teilungseinheiten Anzahl MPP-Tracker: 1 / Anzahl Strings pro MPP: 1 1x Blitzstrom-/Überspannungsableiter Typ 1+2 (PC) 4x Kabelverschraubung M16 2x Kabelverschraubungen M16 für Schutzleiteranschluss Schutzart: IP54
GTIN (EAN)	9003399518027
Ursprungsland	PL
Zolltarifnummer	85371098
Nettogewicht	1,350 kg
Verpackungsmenge	1
Mindestbestellmenge	1

ETIM 8.0	EC003857
----------	----------

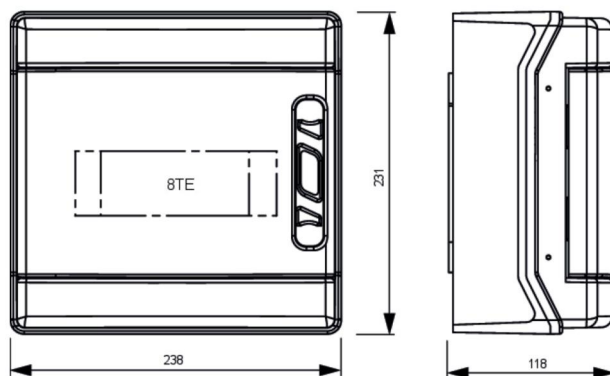

<https://www.pcelectric.at/shop/de/?func=detail&artnr=090PV027>



[www.manufacturer-safety.info](http://www.manufacturer-safety.info)