

# PCE Datenblatt

Artikel-Nr.	<b>090PV005</b>
Bezeichnung	<b>PV-BOX SOL-LINE DC1-MC-TYP1/2 IP54</b>
Langbeschreibung	Systemlösung Typ 1+2 für PV-Anlagen mit 1 MPP-Tracker, 1000V DC Kunststoffgehäuse (238x231x118mm) mit transparentem Fenster für max. 8 Teilungseinheiten Anzahl MPP-Tracker: 1 / Anzahl Strings pro MPP: 1 1x Blitzstrom-/Überspannungsableiter Typ 1+2 (PC) 4x PV-Steckverbinder 2x Kabelverschraubungen M16 für Schutzleiteranschluss fertig verdrahtet Schutzart: IP54
GTIN (EAN)	9003399552892
Ursprungsland	PL
Zolltarifnummer	85371098
Nettogewicht	1,350 kg
Verpackungsmenge	1
Mindestbestellmenge	1
ETIM 8.0	EC003857

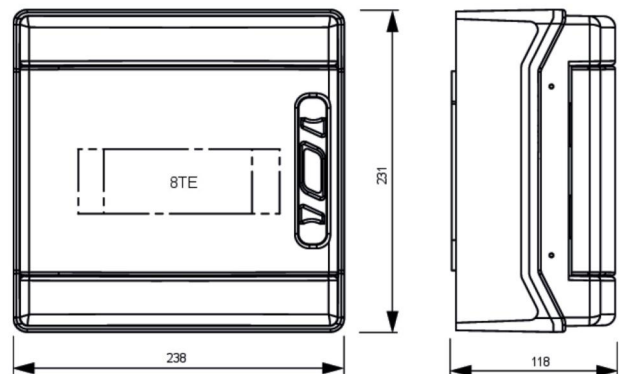

<https://www.pcelectric.at/shop/de/?func=detail&artnr=090PV005>



[www.manufacturer-safety.info](http://www.manufacturer-safety.info)